



CONSTRUCTO 1.0 HRV

Part #41502 (ports on top)

Part #41500 (ports on sides)

45 to 96 CFM (0.4 in. w.g.)



VB0069

AN INGENIOUS AIR EXCHANGE SOLUTION THAT'S AS VERSATILE AS IT IS COMPACT!

Configured with factory built vertical or horizontal ports, the AVS Constructo 1.0 HRV can fit almost anywhere. Hidden in a bulkhead or in a closet, it is the most versatile 100-cfm unit available on the market today. Among its exclusive features, this unit is equipped with integrated balancing and backdraft dampers in its exhaust to outside and fresh air supply ports. For a standard installation, there is no need to balance the unit*, thanks also to its twin high-pressure blowers. Its operation can be interlocked with an existing furnace without adding an extra relay. Also, for more convenience, its latches can be relocated on its front (as shown on unit picture). This compact, lightweight, and powerful unit is the ideal choice for small pre-fab and tract houses, condos, apartments (excluding high rise apartment building) and other limited space applications. What's more, it is the only air exchanger of its size that can be upgraded from an HRV to an ERV, simply by changing its core.

*To avoid balancing, the difference between stale air ducts total length and fresh air ducts total length must not exceed 50 ft.

- 20% smaller than comparable 100-cfm units
- Versatile horizontal or vertical port configuration
- New removable terminal block to ease optional wall control connections
- Integrated pressure taps, if balancing required by building code
- State-of-the-art ventilation technology

REPAIRS AND MAINTENANCE

All parts of the AVS Constructo 1.0 HRV that could need maintenance can be removed in less than five minutes, allowing direct access for easy repairs. The PSC motors are permanently lubricated. Finally, the removable electrical drawer with pull-out PCB assembly allows easy access for maintenance of major sub-components.

WARRANTY

The AVS Constructo 1.0 HRV is protected by a 2-year warranty on parts only. The heat recovery core is covered by a limited lifetime warranty.

Available at:

HEAT RECOVERY VENTILATOR

Controls

- This unit is very simple to operate: once it is installed, press on its push button, located on the bottom of the unit, to activate it. Press once for low speed, once again to high speed, and once more to stop it.
- For more convenience, the following main controls are available:
 - Lite-Touch Constructo #40370
 - Simple-Touch Constructo #40390
 - Constructo #40350
- Also, one to 5 of the following optional controls can be added:
 - 20-min. lighted push button #12030
 - 60-min. mechanical timer #00910

Options

- Complete line of registers and diffusers
- Electric duct heater
- New installation bracket available, part #15390
- Dual exterior hood kit (including the Tandem® transition), part #14690

Homeshield™ Defrosting System

The Constructo 1.0 HRV uses a unique defrosting method. No negative pressure is created by air exhausted to the outside, as the air is recirculated into the house, thus avoiding any backdraft from the chimney.

STALE AIR FROM BUILDING	OUTSIDE TEMPERATURE		DEFROST CYCLE defrosting min. / operating min.
	°C	(°F)	
	Warmer than -5	Warmer than (23)	No defrost
	-5 TO -27	(23 TO 17)	7/25
	-27 & LESS	(-17 & LESS)	10/22

Heat Recovery Core

Dimensions: 13" x 19" x 6 7/8" (33 cm x 48.3 cm x 17.3 cm)

Exchange surface: 55 ft² (5.1 m²)

Weight: 3.75 lb (1.7 kg)

Material: Polypropylene (coroplast)

Type: Crossflow core

Warranty: Limited Lifetime

Requirements and Standards

- Complies with the UL 1812 requirements regulating the installation of Heat Recovery Ventilators
- Complies with the CSA C22.2 #113 Standard applicable to ventilators
- Complies with CSA C444 requirements regulating the installation of Energy Recovery Ventilators
- Technical data was obtained from published results of tests relating to CSA C439 Standards
- HVI certified

Dimensions and Service Clearances: Venmar AVS Constructo 1.0 HRV (ports on sides)

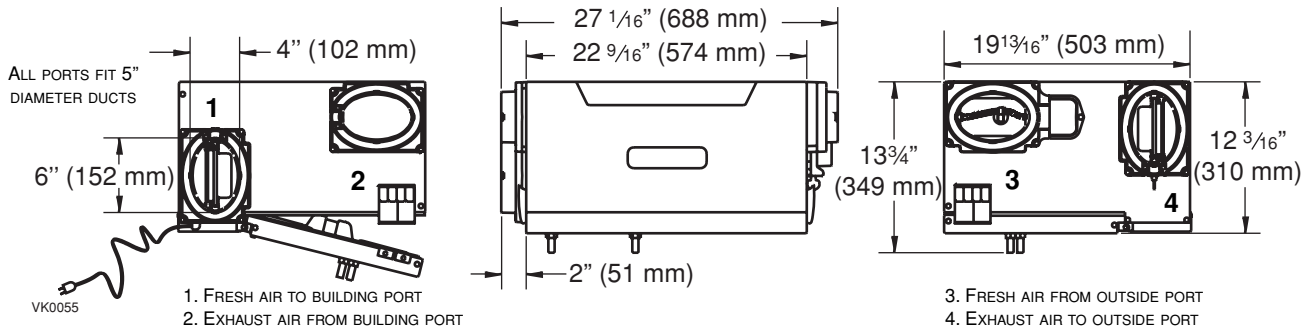

Ventilation Performance

EXT STATIC PRESSURE	NET SUPPLY AIR FLOW					GROSS AIR FLOW				
	Pa	in.w.g.	l/s	cfm	m³/h	SUPPLY	EXHAUST	SUPPLY	EXHAUST	SUPPLY
25	0.1	52	110	187	52	110	187	57	122	205
50	0.2	50	106	180	50	106	180	55	116	198
75	0.3	48	101	173	48	102	173	53	113	191
100	0.4	45	96	162	46	97	166	50	107	180
125	0.5	43	92	155	43	92	155	48	103	173
150	0.6	41	87	148	41	87	148	45	96	162
175	0.7	38	81	137	38	81	137	43	91	155
200	.8	35	75	126	36	76	130	40	85	144

Venmar AVS Constructo 1.0 HRV (ports on top)

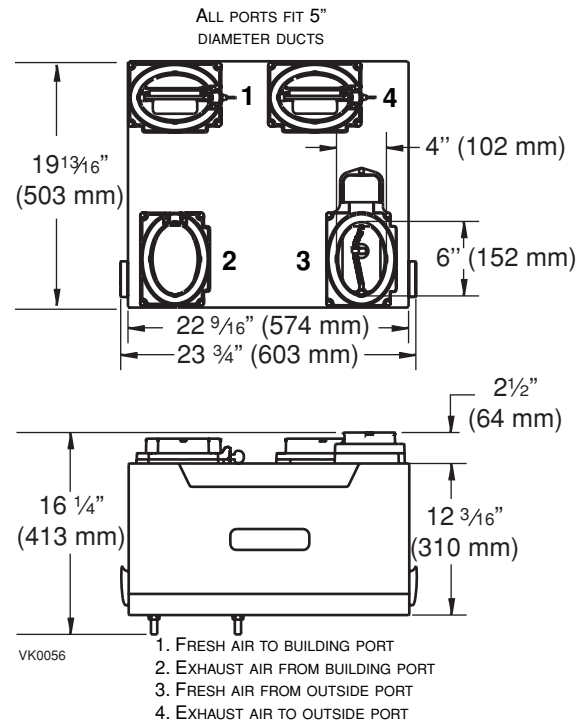

Energy Performance

SUPPLY TEMPERATURE		NET AIR FLOW		POWER CONSUMED	SENSIBLE RECOVERY EFFICIENCY	APPARENT SENSIBLE EFFECTIVENESS	LATENT RECOVERY/MOISTURE TRANSFER
°C	°F	l/s	cfm	WATTS	%	%	%
HEATING							
0	+32	23	48	82	68	78	0.07
0	+32	30	63	108	82	76	0.04
0	+32	44	93	157	116	68	0.04
-25	-13	30	63	108	110	81	0.08
COOLING							
+35	+95	-	-	-	TOTAL RECOVERY EFFICIENCY		
Not tested							

NOTE: All specifications are subject to change without notice.

Specifications and Ratings

- Model: Venmar AVS Constructo 1.0 HRV
- Part Number ports on top: #41502
- Part Number ports on sides #41500
- Total Assembled Weight: (Including polypropylene core): 42 lb (19 kg)
- Oval shaped ports; fit 5" ducts
- Drains: 1/2" (1.2 cm) fittings with 10 ft (3 m) PVC drain
- Core filters: 30 ppi washable foam -10.5" x 6.75" x 0.75" (26.7 x 17.2 x 1.3 cm)

- Cabinet: 20 ga. pre-painted steel
- Insulation: expanded polystyrene
- Mounting: suspension by chains and springs
- Supply & Exhaust Blower Motors: 2 motors
 - Protection type: Thermally protected
 - Insulation class: B
 - V (motor marking): 120 V ac, 60 Hz, 0.6 A, 3000 RPM

- Speed Control on unit: Low and High speed. Other modes available with main and optional wall controls
- Heat Recovery Core:
 - Heat Exchange Surface Area: 55 ft² (5.1 m²)
 - Type/Material: Crossflow / Polypropylene
- Unit Electrical Characteristics:

Volts	Freq	Amperes	Watts
120	60 Hz	1.3	150

Submitted by:		Date:	Project:
Qty:	Model #:	Remarks:	Location:
			Architect:
			Engineer:
			Contractor:



Residential Product Group, 550 Lemire Blvd, Drummondville, QC, Canada J2C 7W9 - Tel.: 1-800-567-3855 Fax: 1-800-567-1715



www.venmar.ca

06/05 PRODUCT SHEET #91047